

**DO NOT OPEN THIS TEST BOOKLET UNTIL YOU ARE ASKED TO DO SO**

T.B.C. : P-RSR-L-ZRB

Test Booklet Series

Serial No.

37141

**TEST BOOKLET**  
**MECHANICAL ENGINEERING**



Paper—II

**Time Allowed : Two Hours**

**Maximum Marks : 200**

**INSTRUCTIONS**

1. IMMEDIATELY AFTER THE COMMENCEMENT OF THE EXAMINATION, YOU SHOULD CHECK THAT THIS TEST BOOKLET DOES **NOT** HAVE ANY UNPRINTED OR TORN OR MISSING PAGES OR ITEMS, ETC. IF SO, GET IT REPLACED BY A COMPLETE TEST BOOKLET.
2. ENCODE CLEARLY THE TEST BOOKLET SERIES A, B, C OR D AS THE CASE MAY BE IN THE APPROPRIATE PLACE IN THE ANSWER SHEET.
3. You have to enter your Roll Number on the Test Booklet in the Box provided alongside. **DO NOT** write *anything else* on the Test Booklet.
4. This Test Booklet contains 120 items (questions). Each item comprises four responses (answers). You will select the response which you want to mark on the Answer Sheet. In case you feel that there is more than one correct response, mark the response which you consider the best. In any case, choose **ONLY ONE** response for each item.
5. You have to mark all your responses **ONLY** on the separate Answer Sheet provided. See directions in the Answer Sheet.
6. All items carry equal marks.
7. Before you proceed to mark in the Answer Sheet the response to various items in the Test Booklet, you have to fill in some particulars in the Answer Sheet as per instructions sent to you with your Admission Certificate.
8. After you have completed filling in all your responses on the Answer Sheet and the examination has concluded, you should hand over to the Invigilator **only the Answer Sheet**. You are permitted to take away with you the Test Booklet.
9. Sheets for rough work are appended in the Test Booklet at the end.
10. **Penalty for wrong answers :**  
THERE WILL BE PENALTY FOR WRONG ANSWERS MARKED BY A CANDIDATE IN THE OBJECTIVE TYPE QUESTION PAPERS.
  - (i) There are four alternatives for the answer to every question. For each question for which a wrong answer has been given by the candidate, **one-third (0.33)** of the marks assigned to that question will be deducted as penalty.
  - (ii) If a candidate gives more than one answer, it will be treated as a **wrong answer** even if one of the given answers happens to be correct and there will be same penalty as above to that question.
  - (iii) If a question is left blank, i.e., no answer is given by the candidate, there will be **no penalty** for that question.

**DO NOT OPEN THIS TEST BOOKLET UNTIL YOU ARE ASKED TO DO SO**

1. Total number of instantaneous centers of rotation for a mechanism having  $n$  links is :
  - (a)  $\frac{n(n-1)}{2}$
  - (b)  $\frac{n}{2}$
  - (c)  $n-1$
  - (d)  $n$
  
2. Consider the following statements pertaining to an example for a cylindrical pair :
  1. Piston and cylinder of an IC engine
  2. Shaft supported by a foot step bearing
  3. Doctor's injection syringe
  4. A screw driver operating on a screw
 Which of these statements are correct ?
  - (a) 1 and 4
  - (b) 2 and 3
  - (c) 1 and 3
  - (d) 3 and 4
  
3. The number of degrees of freedom of an epicyclic gear train is .
  - (a) Zero
  - (b) One
  - (c) Two
  - (d) Three
  
4. The advantages of involute profile over cycloidal are given below. Which of these is NOT correct ?
  - (a) The interference is inherently absent in the involute system
  - (b) In the involute system, the pressure angle is constant from commencement to end of engagement
  - (c) The straight teeth of the basic rack for the involute profile admits of simple tools
  - (d) The profile for the flank and face is a single curve in the involute system
  
5. Flywheel absorbs energy during those periods of crank rotation when .
  - (a) The twisting moment is greater than the resisting moment
  - (b) The twisting moment is equal to the resisting moment
  - (c) The twisting moment is less than the resisting moment
  - (d) The load on the engine falls
  
6. Introduction of the flywheel in a rotating system smoothens :
  - (a) The bending moment on the rotating shaft
  - (b) The twisting moment on the shaft
  - (c) The bending stress on the shaft
  - (d) The axial force along the shaft
  
7. A four stroke six cylinder in line engine symmetrical about centre line can be balanced for :
  - (a) Primary inertia forces and couples only
  - (b) Primary and secondary inertia forces only
  - (c) Secondary inertia forces and couples only
  - (d) All forces and couples
  
8. Given below are four Vee twin engines with different included angles between cylinder axes. Which one of these engines can be completely balanced for primary forces by attaching a single revolving mass opposite to the crank pin ?
  - (a) Vee  $45^\circ$  twin engine
  - (b) Vee  $90^\circ$  twin engine
  - (c) Vee  $60^\circ$  twin engine
  - (d) Vee  $120^\circ$  twin engine
  
9. Large field guns which come to initial position after firing in shortest possible time are :
  - (a) Under damped
  - (b) Critically damped
  - (c) Over damped
  - (d) Un-damped

10. Which of the following type of viscous damping will give periodic motion to the vibrating body ?
1. Under damping
  2. Critical damping
  3. Over damping
- (a) 1 only  
(b) 2 only  
(c) 3 only  
(d) 1 and 2
11. Consider the following statements.  
Transmissibility of vibrations :
1. Is more than 1, when  $\frac{\omega}{\omega_n} < \sqrt{2}$
  2. Is less than 1, when  $\frac{\omega}{\omega_n} > \sqrt{2}$
  3. Increases as the damping is increased
- Which of these statements are correct ?
- (a) 1, 2 and 3  
(b) 1 and 2 only  
(c) 2 and 3 only  
(d) 1 and 3 only
12. Rayleigh's method of computing the fundamental natural frequency is based on :
- (a) Conservation of energy  
(b) Conservation of momentum  
(c) Conservation of masses  
(d) Laws of statics
13. In hydrodynamic journal bearings, if the clearance ratio is halved then the Sommerfeld number  $S$  and the coefficient of friction  $\mu$  will change as :
- (a)  $S$  becomes double and  $\mu$  is halved  
(b)  $S$  becomes four times and  $\mu$  is doubled  
(c)  $S$  becomes four times and  $\mu$  is halved  
(d)  $S$  becomes double and  $\mu$  is also doubled
14. A rope has been designated as  $6 \times 19$ . The numbers 6 and 19 respectively stand for :
- (a) Rope diameter and the number of wires  
(b) Rope diameter and the number of strands  
(c) Number of strands and the number of wires  
(d) Number of wires and the number of strands.
15. If there are  $n_1$  discs on the driving shaft and  $n_2$  discs on the driven shaft in a multi-plate clutch, then the number of pairs of contact surfaces is :
- (a)  $n_1 + n_2$   
(b)  $n_1 + n_2 - 1$   
(c)  $n_1 + n_2 - 2$   
(d)  $n_1 + n_2 + 1$
16. Consider the following statements pertaining to V belts in power transmission :
1. Standard V belts are available in 7 sizes of cross section A to G
  2. Standard V belts are available in 5 sizes of cross section A to E
  3. Standard V belts are available in 5 sizes of cross section A to E with A having largest cross section
  4. The included angle for the belt groove in usually around  $35^\circ$ .
- Which of these statements are correct ?
- (a) 1 only  
(b) 2 and 4  
(c) 3 and 4  
(d) 1 and 4
17. An axle is a machine part that is subjected to :
- (a) Transverse loads and bending moment  
(b) Twisting moment only  
(c) Twisting moment and axial load  
(d) Bending moment and axial load

18. In a bolt of uniform strength :
- Nominal diameter of thread is equal to the diameter of shank of the bolt
  - Nominal diameter of thread is larger than the diameter of shank of the bolt
  - Nominal diameter of thread is less than the diameter of shank of the bolt
  - Core diameter of threads is equal to the diameter of shank of the bolt
19. Interference fit joints are provided for :
- Assembling bush bearing in housing
  - Mounting heavy duty gears on shafts
  - Mounting pulley on shafts
  - Assembly of flywheels on shaft
20. When a journal rotates in anticlockwise direction at high speed in a bearing having adequate supply of lubricant, it will be :
- Pushed to the left of the bearing centre and is likely to have no metal contact with the bearing
  - Resting just below the bearing centre without making metal to metal contact
  - Pushed to the right of the bearing centre and make no metal to metal contact
  - Running concentric with the bearing centre and make no metal to metal contact
21. In wire ropes which one of the following statements is correct ?
- Bending stress is directly proportional to the wire diameter and inversely proportional to the sheave diameter
  - Both fatigue and wear are due to the tensile stress on the wires bearing against the sheave
  - Bending stress is inversely proportional to the wire diameter and directly proportional to sheave diameter
  - Both fatigue and wear are due to shear stress on the wires bearing against the sheave

22.

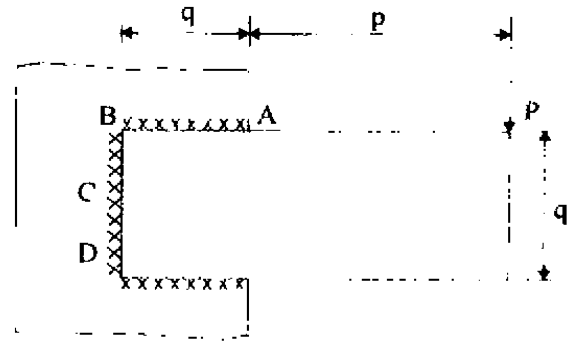

A compound fillet welded joint is loaded by  $P$  as shown. The maximum shearing stress occurs at point :

- A and D
  - B and D
  - A only
  - C only
23. A fillet weld is loaded parallel to its length  $l$  by a load  $P$ . If the weld leg is  $h$ , the average shear stress on the throat area is :
- $\frac{P}{h}$
  - $\frac{P}{0.5hl}$
  - $\frac{2P}{hl}$
  - $1.414 \frac{P}{h}$
24. Bevel gears having equal number of teeth and equal pitch angles connect two orthogonally intersecting shafts. This system of gears is known as :
- Crown gears
  - Hypoid gears
  - Worm gears
  - Mitre gears
25. A solid steel shaft of diameter  $d$  and length  $l$  is subjected to twisting moment  $T$ . Another shaft B of brass having same diameter  $d$ , but length  $l/2$  is also subjected to the same moment. If shear modulus of steel is two times that of brass, the ratio of the angular twist of steel to that of brass shaft is :
- 1 : 2
  - 1 : 1
  - 2 : 1
  - 4 : 1

26. A high pressure angle for spur gears leads to :
- Minimum axial thrust
  - Greater backlash
  - More interference
  - Wide base and stronger tooth
27. Match List-I with List-II and select the correct answer using the code given below the lists :

List-I

List-II

- |                       |            |
|-----------------------|------------|
| A. Unwin's formula    | 1. Bearing |
| B. Wahl factor        | 2. Rivets  |
| C. Reynold's equation | 3. Gears   |
| D. Lewis form factor  | 4. Springs |

Code :

- |     | A | B | C | D |
|-----|---|---|---|---|
| (a) | 3 | 1 | 4 | 2 |
| (b) | 2 | 1 | 4 | 3 |
| (c) | 3 | 4 | 1 | 2 |
| (d) | 2 | 4 | 1 | 3 |

28. Antifriction bearings are normally used in shafts :
- Running at 20,000 to 40,000 rpm
  - Running at speeds up to 6,000 rpm
  - Of diameters up to 500 mm
  - Of diameter more than 500 mm
- 1 and 3
  - 2 and 3
  - 2 and 4
  - 1 and 4

29.

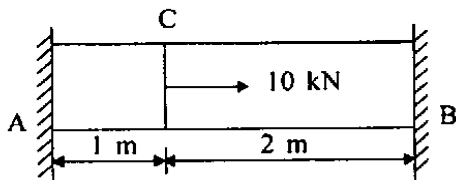

A prismatic bar, as shown in figure is supported between rigid supports. The support reactions will be :

- $R_A = \frac{10}{3}$  kN and  $R_B = \frac{20}{3}$  kN
- $R_A = \frac{20}{3}$  kN and  $R_B = \frac{10}{3}$  kN
- $R_A = 10$  kN and  $R_B = 10$  kN
- $R_A = 5$  kN and  $R_B = 5$  kN

30.

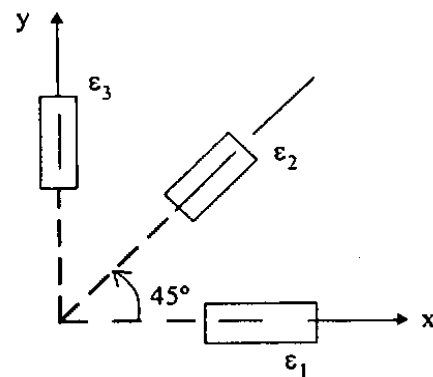

A rectangular strain rosette, shown in figure, gives following readings in a strain measurement task,  $\epsilon_1 = 1000 \times 10^{-6}$ ,  $\epsilon_2 = 800 \times 10^{-6}$  and  $\epsilon_3 = 600 \times 10^{-6}$ . The direction of the major principal strain with respect to gauge 1 is :

- $0^\circ$
- $15^\circ$
- $30^\circ$
- $45^\circ$

31. If a piece of material neither expands nor contracts in volume when subjected to stresses, then the Poisson's ratio must be :
- Zero
  - 0.25
  - 0.33
  - 0.5

32.

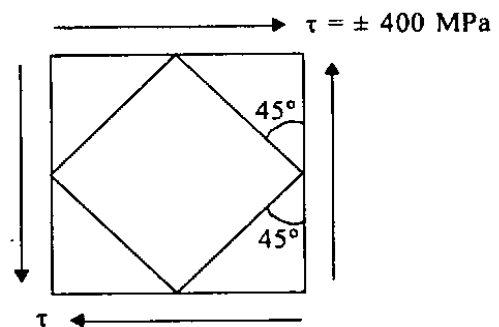

What are the normal and shear stresses on the  $45^\circ$  planes shown ?

- $\sigma_1 = -\sigma_2 = 400$  MPa and  $\tau = 0$
- $\sigma_1 = \sigma_2 = 400$  MPa and  $\tau = 0$
- $\sigma_1 = \sigma_2 = -400$  MPa and  $\tau = 0$
- $\sigma_1 = \sigma_2 = \tau = \pm 200$  MPa

33. Materials which show direction dependent properties are called :
- Homogeneous
  - Viscoelastic
  - Isotropic
  - Anisotropic
34. If a rod expands freely due to heating, it will develop
- Bending stress
  - Thermal stress
  - No stress
  - Compressive stress
35. Match List-I with List-II and select the correct answer using the code given below the lists :

<i>List-I</i>	<i>List-II</i>
A. Subjected to bending moment at the end of a cantilever	1. Triangle
B. Cantilever carrying uniformly distributed load over the whole length	2. Cubic Parabola
C. Cantilever carrying linearly varying load from zero at the free end to maximum at the supports	3. Parabola
D. A beam having load at centre and supported at the ends	4. Rectangle

Code :

	A	B	C	D
(a)	1	2	3	4
(b)	4	3	2	1
(c)	1	3	2	4
(d)	4	2	3	1

36. A T-section beam is simply supported and subjected to a uniform distributed load over its whole span. Maximum longitudinal stress in the beam occurs at :
- Top fibre of the flange
  - The junction of web and flange
  - The mid-section of the web
  - The bottom fibre of the web
37. For the two shafts connected in parallel :
- Torque in each shaft is the same
  - Shear stress in shaft is the same
  - Angle of twist of each shaft is the same
  - Torsional stiffness of each shaft is the same
38. Two equal lengths of steel wires of the same diameter are made into two springs  $S_1$  and  $S_2$  of mean diameters 75 mm and 60 mm respectively. The stiffness ratio of  $S_1$  to  $S_2$  is :
- $\left(\frac{60}{75}\right)^2$
  - $\left(\frac{60}{75}\right)^3$
  - $\left(\frac{75}{60}\right)^2$
  - $\left(\frac{75}{60}\right)^3$
39. Solid material chemical bonds are :
- Ionic, molecular and fusion
  - Covalent, fusion and fission
  - Ionic, covalent and molecular
  - Fission, molecular and ionic
40. Cleavage fracture is a form of .
- Brittle fracture
  - Ductile fracture
  - Elastic fracture
  - Viscoelastic fracture

41. Match List-I with List-II and select the correct answer using the code given below the lists :

<i>List-I</i>	<i>List-II</i>
A. Alpha iron	1. FCC
B. Zinc	2. BCC
C. Glass	3. HCP
D. Copper	4. Amorphous

Code :

	A	B	C	D
(a)	1	4	3	2
(b)	2	4	3	1
(c)	1	3	4	2
(d)	2	3	4	1

42. In a triclinic unit cell :

- (a)  $\alpha = \beta = \gamma = 90^\circ$
- (b)  $\alpha = \beta = 90^\circ, \gamma = 120^\circ$
- (c)  $\alpha = \beta = 90^\circ \neq \gamma$
- (d)  $\alpha \neq \beta \neq \gamma \neq 90^\circ$

43. Structure of common glass is :

- (a) Amorphous
- (b) Partially crystalline
- (c) Fully crystalline
- (d) None of the above

44. Liquid + solid (1) on cooling converting into solid (2) reaction is known as :

- (a) Eutectoid reaction
- (b) Eutectic reaction
- (c) Peritectic reaction
- (d) Peritectoid reaction

45. Match List-I with List-II and select the correct answer using the code given below the lists :

<i>List-I</i>	<i>List-II</i>
A. System	1. Free energy is a minimum
B. Phase	2. Chemical elements or chemical compounds
C. Phase equilibrium	3. Consists of solids, liquids or gases or their combination
D. Components	4. Homogeneous portion of a system that has uniform physical characteristics

Code :

	A	B	C	D
(a)	2	1	4	3
(b)	3	1	4	2
(c)	2	4	1	3
(d)	3	4	1	2

46. Babbit is an alloy of :

- (a) Sn, Cu, Sb and Pb
- (b) Sn and Cu
- (c) Sn, Cu and Pb
- (d) Sn, Cu and Sb

47. Resilience of a material becomes important when it is subjected to :

- (a) Fatigue
- (b) Thermal stresses
- (c) Shock loading
- (d) Pure static loading

48. During tensile testing it has been observed that for some material the deformation is fully recoverable and time-independent, but does not obey Hook's law. The material is :
- Elastomer
  - Rubber
  - Polymer
  - Aluminium alloy

49. Match List-I with List-II and select the correct answer using the code given below the lists :

<i>List-I</i>	<i>List-II</i>
A. Copper	1. Corrosion
B. Nickel	2. Demagnetization
C. Manganese	3. Non sparking
D. Vanadium	4. Deformation restriction at high temperature

Code :

	A	B	C	D
(a)	1	2	3	4
(b)	4	3	2	1
(c)	1	3	2	4
(d)	4	2	3	1

50. Match List-I with List-II and select the correct answer using the code given below the lists :

<i>List-I</i>	<i>List-II</i>
A. Elasticity	1. Deform non elastically without fracture
B. Malleability	2. Undergo plastic deformation under tensile load
C. Ductility	3. Undergo plastic deformation under compressive load
D. Plasticity	4. Return to its original shape on unloading

Code :

	A	B	C	D
(a)	1	2	3	4
(b)	4	2	3	1
(c)	1	3	2	4
(d)	4	3	2	1

51. The relationship between total freezing time  $t$ , volume of the casting  $V$  and its surface area  $A$ , according to Chvorinov's rule is :

- $t = K \left( \frac{V}{A} \right)$
- $t = K \left( \frac{A}{V} \right)$
- $t = K \left( \frac{A}{V} \right)^2$
- $t = K \left( \frac{V}{A} \right)^2$

Where  $K$  is a constant

52. Which one of the following statements is **NOT** correct for normalizing ?

- It is often applied to castings to relieve stresses
- It increases strength of medium carbon steel to some extent
- Better surface finish can be obtained in machining
- It increases grain size

53. 'Whiskers' are :

- Very thin metallic particles
- Very thin single crystals
- Very thin polycrystals
- Fiber particles of aspect ratio less than 10

54. Injection moulding process used to produce thermoplastic matrix composites with fibre reinforcement normally gives :

- Short fibre composites
- Two layer structure composites
- Continuous fibre composites
- Single layer composites

55. Aluminium Bronze is also known as :

- Muntz metal
- White metal
- Duraluminium
- Imitation gold



56. Match List-I with List-II and select the correct answer using the code given below the lists :

<i>List-I</i>	<i>List-II</i>
A. Gun metal	1. Worm wheel
B. Phosphor bronze	2. Cylinder block
C. Gray cast iron	3. Piston
D. Al alloy	4. Bushings

Code :

	A	B	C	D
(a)	3	1	2	4
(b)	4	1	2	3
(c)	3	2	1	4
(d)	4	2	1	3

57. Lead is widely used in :

- (a) Transformers
- (b) Switch gear
- (c) Galvanized pipes
- (d) Batteries

58. Kevlar Epoxy composite is widely used in :

- (a) Automobiles
- (b) Aerospace
- (c) Navy
- (d) Interior decoration

59. Windows of aeroplane are made of :

- (a) PVC
- (b) PTFE
- (c) PMMA
- (d) PEEK

60. Admiralty Brass is used for :

- (a) Condenser tubes
- (b) Rivets
- (c) Piston rods
- (d) Utensils

61. Which one of the following is the major alloying element in Invar ?

- (a) Aluminium
- (b) Nickel
- (c) Vanadium
- (d) Copper

62. In the designation of Aluminium casting **A514·0 14** indicates :

- (a) Aluminium purity
- (b) Aluminium content
- (c) Percentage of alloy element
- (d) Magnesium content

63. Columbium is a :

- (a) Nuclear material
- (b) Automobile material
- (c) Film material
- (d) Foam material

64. Consider the following statements :

1. Any metal will require some time to undergo complete plastic deformation particularly if deforming metal has to fill cavities and corners of small radii.
2. For larger work piece of metals that can retain toughness at forging temperature it is preferable to use forge press rather than forge hammer.

- (a) 1 and 2 are correct and 2 is the reason for 1
- (b) 1 and 2 are correct and 1 is the reason for 2
- (c) 1 and 2 are correct but unrelated
- (d) 1 only correct

65. Which of the following processes belong to forging operation ?

1. Fullering
2. Swaging
3. Welding

- (a) 1 and 2 only
- (b) 2 and 3 only
- (c) 1 and 3 only
- (d) 1, 2 and 3

66. Match List-I with List-II and select the correct answer using the code given below the lists :

*List-I*

*List-II*

- |                      |              |
|----------------------|--------------|
| A. Connecting rods   | 1. Welding   |
| B. Pressure vessels  | 2. Extrusion |
| C. Machine tool beds | 3. Forming   |
| D. Collapsible tubes | 4. Casting   |

Code :

<b>A</b>	<b>B</b>	<b>C</b>	<b>D</b>
----------	----------	----------	----------

- (a) 2 1 4 3
- (b) 3 1 4 2
- (c) 2 4 1 3
- (d) 3 4 1 2

67. Consider the following statements :

1. Hot chamber machine is used for casting zinc, tin and other low melting alloys
2. Cold chamber machine is used for die casting of ferrous alloys
3. Rapid cooling rate in die casting produces high strength and quality in many alloys

Which of these statements are correct ?

- (a) 1, 2 and 3
- (b) 1 and 2 only
- (c) 2 and 3 only
- (d) 1 and 3 only

68. Consider the following advantages of die casting over sand casting :

1. Rapidity of the process
2. Smooth surface
3. Strong dense metal structure

Which of these advantages are correct ?

- (a) 1, 2 and 3
- (b) 1 and 2 only
- (c) 2 and 3 only
- (d) 1 and 3 only

69. The proper sequence of investment casting steps is :

- (a) Slurry coating - Pattern melt out - Shakeout - Stucco coating
- (b) Stucco coating - Slurry coating - Shakeout - Pattern melt out
- (c) Slurry coating - Stucco coating - Pattern melt out - Shakeout
- (d) Stucco coating - Shakeout - Slurry coating - Pattern melt out

70. The methods of casting for producing ornamental pieces are :

- (a) Slush and gravity casting
- (b) Pressed and slush casting
- (c) Gravity and semi permanent mould casting
- (d) Semi permanent mould and pressed casting

71. In light metal castings, runner should be so designed that :

1. It avoids aspiration
  2. It avoids turbulence
  3. The path of runner is reduced in area so that unequal volume of flow through each gate takes place
- (a) 1 and 2 only
  - (b) 1 and 3 only
  - (c) 2 and 3 only
  - (d) 1, 2 and 3

72. During plasma arc welding of aluminium, improved removal of the surface oxide from the base metal is obtained with typical polarity of :

- (a) DC straight
- (b) DC reverse
- (c) AC potential
- (d) Reverse polarity of phase of AC potential

73. The welding process in which bare wire is used as electrode, granular flux is used and the process is characterized by its high speed welding, is known as :

- (a) Shielded arc welding
- (b) Plasma arc welding
- (c) Submerged arc welding
- (d) Gas metal arc welding

74. Consider the following statements.

Cast iron is difficult to weld, because of :

1. Low ductility
2. Poor fusion
3. Tendency to crack on cooling

Which of these statements are correct ?

- (a) 1, 2 and 3
- (b) 1 and 2 only
- (c) 2 and 3 only
- (d) 1 and 3 only

75. Match List-I with List-II and select the correct answer using the code given below the lists :

*List-I*

*List-II*

- |                          |   |
|--------------------------|---|
| A. Laser beam welding    | 1. Can be applied for welding of refractory metals like niobium, tantalum, molybdenum and tungsten  |
| B. Electron beam welding | 2. A sound and clean welded joint is created due to rubbing of two parts against each other with adequate speed and pressure producing intense heat raising temperature above melting point |
| C. Ultrasonic welding    | 3. Clean heat source created much away from job, a narrow spot is heated, work chamber operates in a high vacuum  |
| D. Friction welding      | 4. Clean heat source, very quick heating, very small focal spot, no vacuum chamber is required  |

*Code :*

- |     | A | B | C | D |
|-----|---|---|---|---|
| (a) | 4 | 3 | 1 | 2 |
| (b) | 2 | 3 | 1 | 4 |
| (c) | 4 | 1 | 3 | 2 |
| (d) | 2 | 1 | 3 | 4 |

76. Cold-cracking in steel weldments depends on :
1. Carbon equivalent
  2. Heat input
  3. Effective thickness
  4. Hydrogen content in weld pool
- (a) 1, 2 and 3 only  
 (b) 1, 2 and 4 only  
 (c) 2, 3 and 4 only  
 (d) 1, 2, 3 and 4
77. In Norton type feed gearbox for cutting Whitworth standard threads with a standard TPI Leadscrew, power flows from :
- (a) Spindle to Tumbler gear to Norton cone to Meander drive to Leadscrew  
 (b) Spindle to Norton cone to Tumbler gear to Meander drive to Leadscrew  
 (c) Spindle to Tumbler gear to Meander drive to Norton cone to Leadscrew  
 (d) Spindle to Norton cone to Meander drive to Tumbler gear to Leadscrew
78. Match List-I with List-II and select the correct answer using the code given below the lists :
- | <i>List-I</i>       | <i>List-II</i>        |
|---------------------|-----------------------|
| A. Lathe            | 1. Flute              |
| B. Shaper           | 2. Universal indexing |
| C. Drilling machine | 3. Leadscrew          |
| D. Milling machine  | 4. Rocker arm         |
- Code :*
- |     | A | B | C | D |
|-----|---|---|---|---|
| (a) | 2 | 4 | 1 | 3 |
| (b) | 3 | 4 | 1 | 2 |
| (c) | 2 | 1 | 4 | 3 |
| (d) | 3 | 1 | 4 | 2 |
79. Trajectory of a robot means :
- (a) Path traced by the end effector  
 (b) Kinematics of Robot  
 (c) Robot joints  
 (d) Robot programming
80. Typical coolants used for machining aluminium are :
1. Kerosene oil
  2. Soda water
  3. Air
  4. Paraffin oil
- (a) 1, 2, 3 and 4  
 (b) 2 and 3 only  
 (c) 1 and 2 only  
 (d) 3 and 4 only
81. The instrument or device used to measure the cutting forces in machining is :
- (a) Tachometer  
 (b) Comparator  
 (c) Dynamometer  
 (d) Lactometer
82. In a transportation problem, how is an unacceptable transportation route handled ?
- (a) By giving it a cost of zero  
 (b) By carrying an extremely high cost  
 (c) By introducing a dummy destination  
 (d) By introducing a dummy origin
83. Consider the following characteristics :
1. It is very sensitive to small movements in the data
  2. The technique is simple
  3. The method is affected by the personal prejudice of the people
- Which of these characteristics of moving average method of forecasting are correct ?
- (a) 1, 2 and 3  
 (b) 1 and 2 only  
 (c) 2 and 3 only  
 (d) 1 and 3 only

84. The break-even point can be lowered by :
- Increasing the fixed costs
  - Increasing the variable costs
  - Decreasing the slope of the income line
  - Reducing the variable cost
85. The under capacity of a manufacturing company is preferred when :
- The rate of obsolescence of the plant and equipment is high
  - The time required to add capacity is long
  - The fixed cost of the capacity is not very high
  - Shortage of the products affects the company
86. Which one of the following statement is NOT correct with reference to the purposes and effects of rake angle of a cutting tool ?
- To guide the chip flow direction
  - To reduce the friction between the tool flanks and the machined surface
  - To add keenness or sharpness to the cutting edge
  - To provide better thermal efficiency
87. The component reliability is usually measured by : reliability (CR), failure rates (FR) and mean time between failures (MTBF). The MTBF is :
- Number of failures/unit-hours of operation
  - Unit-hours of operation/number of failures
  - Number of failures/number of tested
  - Number of failures  $\times$  unit-hours of operation
88. A basic feasible solution of an  $m \times n$  transportation problem is said to be non degenerate if the allocations are in independent positions and starting basic feasible solution contains exactly following number of individual allocations :
- $m + n$
  - $m \times n$
  - $m + n - 1$
  - $m + n + 1$

89. Consider the following terms used to study the functions of the material :

- Use value
- Esteem value
- Exchange value
- Scrap value

Which of these are used to identify in the value engineering approach ?

- 1, 2, 3 and 4
- 1, 3 and 4 only
- 1, 2 and 3 only
- 2, 3 and 4 only

90. Which of the following method is NOT used for obtaining the initial basic feasible solution in transportation problems ?

- North west corner method
- Least cost entry method
- Vogel's approximation method
- MODI method

91. Match List-I with List-II and select the correct answer using the code given below the lists :

<i>List-I</i>	<i>List-II</i>
A. R	1. Ranges
B. p	2. Number of defects/unit
C. c	3. Number of defects
D. u	4. Fraction defectives

Code :

	A	B	C	D
(a)	1	4	3	2
(b)	2	4	3	1
(c)	1	3	4	2
(d)	2	3	4	1

92. An unbound solution of a linear programming problem is reflected in the simplex method, when :
- All the ratio of 'right hand sides' to coefficients in key column become negative
  - All the ratios of right hand sides to coefficients in key columns become zero
  - All right hand sides become negative
  - All right hand sides become zero
93. When the ordering cost is increased to 4 times, the EOQ will be increased to :
- 2 times
  - 3 times
  - 8 times
  - Remain same
94. For a single server queue, the mean arrival rate is equal to 8/hr and the mean service rate is 12/hr. The expected number in waiting line is equal to .
- 0.5
  - 1.33
  - 2
  - 3
95. In the queuing theory, if the arrivals in a single server model follow Poisson distribution, the time between arrivals will follow a :
- Gamma distribution
  - Exponential distribution
  - Binomial distribution
  - Weibull distribution
96. Which of the following are the advantages of MOS devices over bipolar devices ?
- Easy to fabricate
  - Allows higher bit densities
  - Cost effective
  - Operational speed.
- 1, 2, 3 and 4
  - 1, 2 and 3 only
  - 2, 3 and 4 only
  - 1, 3 and 4 only
97. The number of RAM chips of size (256 k×1) required to build a 2 Mbyte memory is :
- 16
  - 32
  - 64
  - 128
98. Refreshing circuit is required in :
- ROM
  - Static RAM
  - Dynamic RAM
  - All of the above
99. Which of the following statement(s) is/are correct ?
- Bus is a group of wires carrying information
  - Bus can carry data
  - Bus cannot carry address
  - A bus can be shared by more than one device
- 1, 2, 3 and 4
  - 1, 2 and 3 only
  - 1, 2 and 4 only
  - 2, 3 and 4 only

100. In flowcharting, the connector symbol is a :

- (a) Parallelogram
- (b) Square
- (c) Diamond
- (d) Circle

101. Which of the following are the advantages of flowchart ?

- 1. A flowchart is independent of language
  - 2. It is easy to develop a program with flowchart
  - 3. If there are any changes in the program, it is very easy to make changes
- (a) 1 and 2 only
  - (b) 1 and 3 only
  - (c) 2 and 3 only
  - (d) 1, 2 and 3

102. In flowcharting, a parallelogram would be used to represent :

- (a) Getting a keyboard entry from the user
- (b) The beginning of the flowchart
- (c) A decision point that determines which of two branches to follow
- (d) A mathematical calculation

103. USM has good machining performance for :

- (a) Al
- (b) Steel
- (c) Super alloys
- (d) Refractory material

104. Consider the following statements :

- 1. Create a database alias
- 2. Create the tables needed
- 3. Create indexes
- 4. Create a directory for the tables

What is the correct sequence of order for creating a new database in dBase ?

- (a) 4-2-1 and 3
- (b) 3-1-2 and 4
- (c) 4-1-2 and 3
- (d) 3-2-1 and 4

105. Match List-I with List-II and select the correct answer using the code given below the lists :

*List-I*

*List-II*

- |              |                |
|--------------|----------------|
| A. Worksheet | 1. dBase III   |
| B. Records   | 2. C language  |
| C. Pointers  | 3. FORTRAN     |
| D. Compiler  | 4. Lotus 1-2-3 |

*Code :*

- |     | A | B | C | D |
|-----|---|---|---|---|
| (a) | 4 | 2 | 1 | 3 |
| (b) | 3 | 2 | 1 | 4 |
| (c) | 4 | 1 | 2 | 3 |
| (d) | 3 | 1 | 2 | 4 |

106. High energy rate forming process used for forming components from thin metal sheets or deform thin tubes is :

- (a) Petro-forming
- (b) Magnetic pulse forming
- (c) Explosive forming
- (d) Electro-hydraulic forming

107. In the 3-2-1 principle of fixture design, 3 refers to number of :

- (a) Setups possible
- (b) Clamps required
- (c) Positions on primary face
- (d) Locating positions

108. The optimum cutting speed is one which should have :

- 1. High metal removal rate
  - 2. High cutting tool life
  - 3. Balance the metal removal rate and cutting tool life.
- (a) 1, 2 and 3
  - (b) 1 and 2 only
  - (c) 2 and 3 only
  - (d) 3 only

109. Stellite is a non-ferrous cast alloy composed of :
- (a) Cobalt, chromium and tungsten
  - (b) Tungsten, vanadium and chromium
  - (c) Molybdenum, tungsten and chromium
  - (d) Tungsten, molybdenum, chromium and vanadium

110. External threads can be produced by :
- 1. Rolling
  - 2. Grinding
  - 3. Milling
- (a) 1 and 3 only
  - (b) 1 and 2 only
  - (c) 2 and 3 only
  - (d) 1, 2 and 3

111. Match List-I with List-II and select the correct answer using the code given below the lists :

<i>List-I</i>	<i>List-II</i>
A. Top gate	1. Heavy and large castings
B. Bottom gate	2. Most widely used and economical
C. Parting gate	3. Turbulence
D. Step gate	4. Unfavourable temperature gradient

Code :

	A	B	C	D
(a)	3	4	2	1
(b)	1	4	2	3
(c)	3	2	4	1
(d)	1	2	4	3

**Directions :—**

Each of the next **Nine (9)** items consists of two statements, one labeled as the 'Assertion (A)' and the other as 'Reason (R)'. You are to examine these two statements carefully and select the answers to these items using the codes given below :

*Codes :*

- (a) Both A and R are individually true and R is the correct explanation of A
- (b) Both A and R are individually true but R is **NOT** the correct explanation of A
- (c) A is true but R is false
- (d) A is false but R is true

112. Assertion (A) : The centrifugal tension in a belt is  $T_c = mv^2$ .

Reason (R) : Since this expression is independent of the cross-section, it follows that  $T_c$  is independent of the belt size.

113. Assertion (A) : Hot tears occur during forging because of inclusions in the blank material.

Reason (R) : Bonding between the inclusions and the parent material is through physical and chemical bonding.



114. Assertion (A) : Lead, Zinc and tin are always hot worked.

Reason (R) : If they are worked in cold state they cannot retain their mechanical properties.

115. Assertion (A) : Excess defects are created by hammering the crystalline materials.

Reason (R) : The thermal fluctuations create the point defects in crystalline materials.

116. Assertion (A) : Solid solutions of metal are crystals whose properties are close to those of the solvent.

Reason (R) : They retain the same crystal lattice and type of bond.

117. Assertion (A) : Carburizing is used for machine elements which have to have a wear resistant working surface.

Reason (R) : The composition of surface layers are changed in carburizing.

118. Assertion (A) : The steel when heated above a certain temperature and cooled to room temperature, structure adjustment stabilizes.

Reason (R) : The modification is mainly based on cooling rate.

119. Assertion (A) : The plastic organic materials can be easily shaped or moulded by mechanical action.

Reason (R) : It is widely in use as it can be permanently moulded.

120. Assertion (A) : A composite is a multiphase material which is artificially made as one that occurs naturally.

Reason (R) : Technology of modern age requires a material with unusual combination of properties that cannot be met by metal or alloys.

**SPACE FOR ROUGH WORK**

**SPACE FOR ROUGH WORK**

# **SPACE FOR ROUGH WORK**